

# COLONNE SONORE EN ALUMINIUM

D03-51-3016-CA40-V230212

Page 1/1

**CA40**  
**Code 3016**

## DESCRIPTION

- Colonne alliant l'esthétique aux performances acoustiques
- Intégration facile dans tout environnement
- Châssis rigide antivibration en aluminium extrudé avec grille en aluminium
- Haut-parleurs bicône large bande à membrane siliconée
- Transformateurs imprégnés
- Montage aisé par équerre
- Idéales pour les locaux réverbérants exigeant une directivité accentuée.



## SPECIFICATIONS TECHNIQUES

Puissance Nominal (100V)	Watts	64
Puissance Maximum	Watts	90
Domaine utile des Fréquences	Hertz	150-20000
Pression Acoustique 1w (Totale)/1m dB		88-(106)
Connexion	Connecteur à bornes interne	
Multi-Impédances (par cavalier)	Ohms	0,15/0,3/0,6/1,25K
Puissance	Watts	64/32/16/8
Dimensions emballage: LxHxP	mm	110x110x1205
Poids avec emballage	Kg	5,5

## SCHEMA

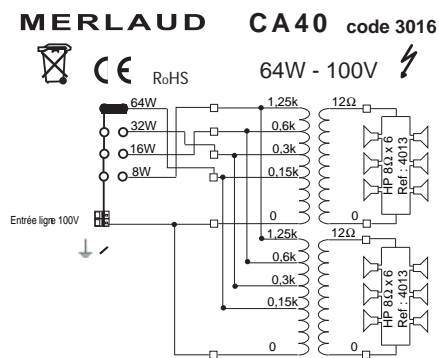

## DIMENSIONS

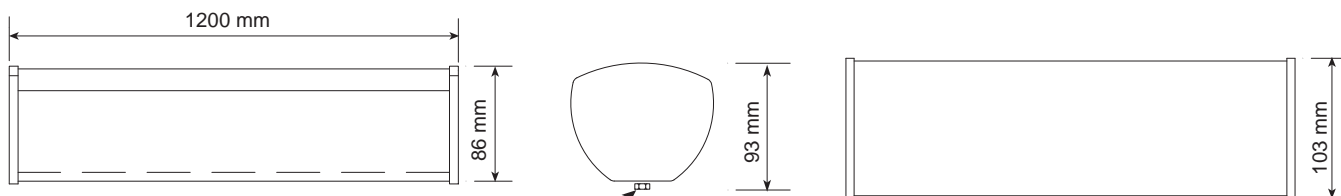

Dimensions : mm

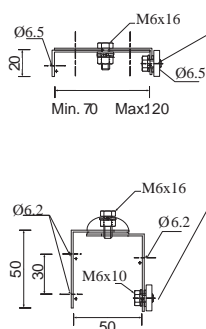
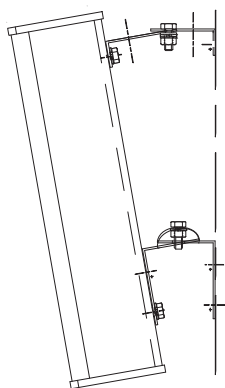

## MONTAGE

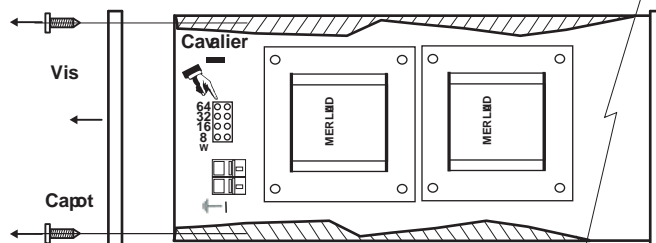

- Retirer les vis.
- Enlever le capot.
- Positionner le cavalier sur la puissance que vous souhaitez.

SPECIFICATIONS SUBJECT TO MODIFICATIONS

DOCUMENT NON CONTRACTUEL



**MERLAUD**

9 rue de La Briqueterie - P.A.E. des FAUVETTES - 95330 DOMONT (FRANCE)  
Tel. 01 39 91 77 78 - Fax 01 39 91 90 66 - [www.merlaud.com](http://www.merlaud.com) - [merlaud@merlaud.com](mailto:merlaud@merlaud.com)

D03-51 FT NT V040412

# ALUMINIUM COLUMN SPEAKER

D03-51-3016-CA40-V230212

Page 1/1

## DESCRIPTION

- Aesthetic with high performance column speaker.
- Extruded no-vibrating rigid aluminium body with aluminium grille.
- Dual cones wide band silicon treated speaker.
- Impregnated low insertion loss multi-taps transformer.
- Easy mounting with Tilting bracket.
- High directivity speaker ideal for reverberant halls and rooms.



## TECHNICAL SPECIFICATIONS

Nominal Power (100V)	Watts	64
Maximum Power	Watts	90
Frequency response	Hertz	150-20000
SPL (max) 1W@1m	dB	88-(107)
Connection	Push-block connector (internal)	
Jumper selectable Power	Watts	64/32/16/8
Impedances	Ohms	0,15/0,3/0,6/1,25k
Pack dimensions : WxHxD	mm	110x110x1205
Pack Weight	Kg	5,5

## WIRING

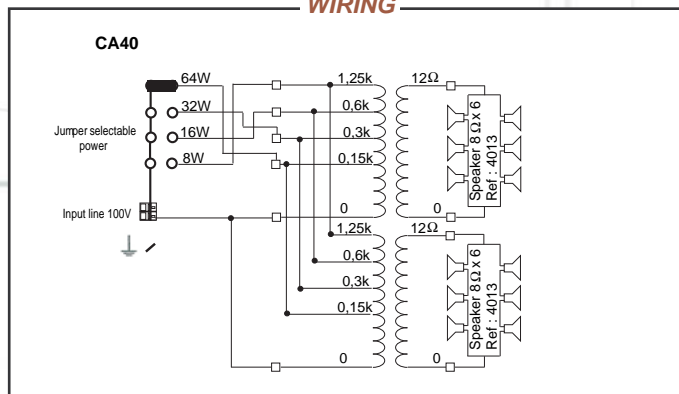

## DIMENSIONS

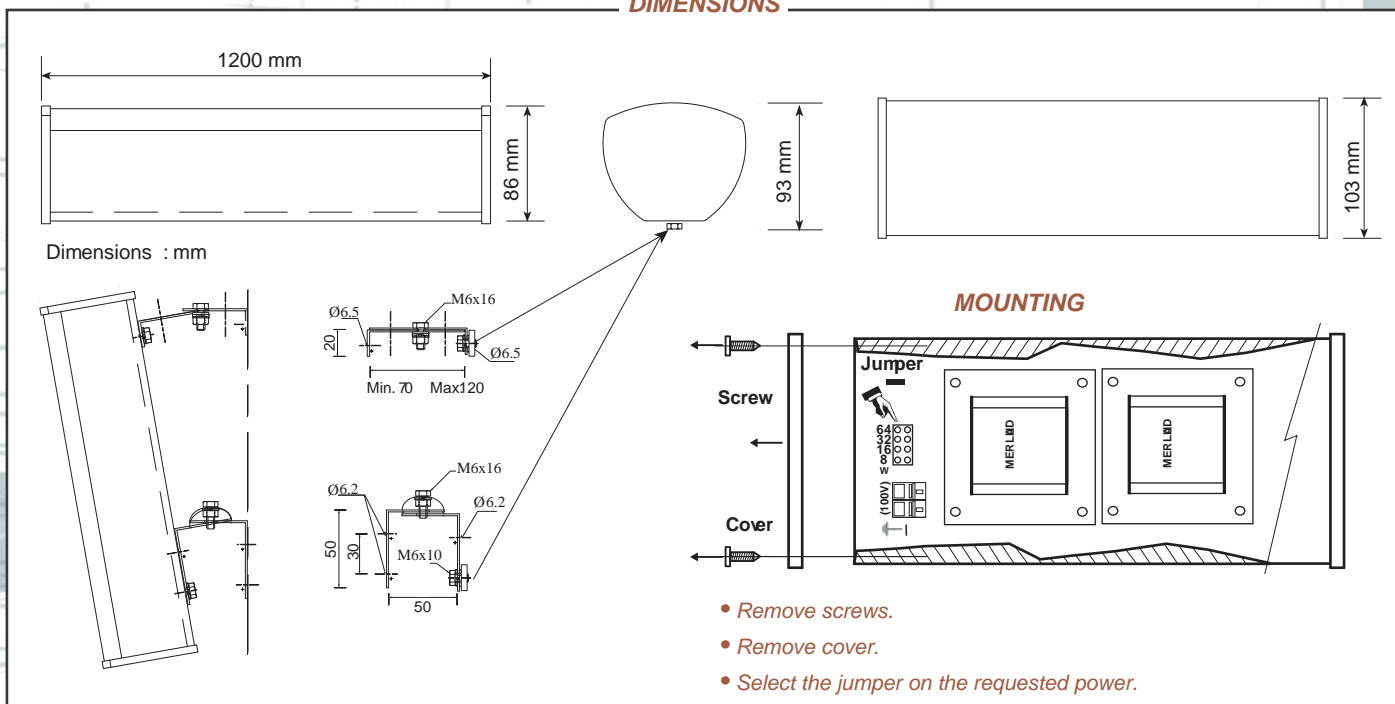

SPECIFICATIONS SUBJECT TO MODIFICATIONS

DOCUMENT NON CONTRACTUEL



**MERLAUD**

9 rue de La Briqueterie - P.A.E. des FAUVETTES - 95330 DOMONT (FRANCE)  
Tel. 01 39 91 77 78 - Fax 01 39 91 90 66 - [www.merlaud.com](http://www.merlaud.com) - [merlaud@merlaud.com](mailto:merlaud@merlaud.com)